

SLS-TME-TA-2005-0264
5th April 2005

Gun Test Stand Solenoid Measurements

Simon C. Leemann, Åke Andersson

Paul Scherrer Institut, CH-5232 Villigen PSI, Switzerland

Abstract

In the scope of the LEG Project [1] it has been decided to build a 100 keV gun test stand. In this test stand, we attempt to compensate emittance blow-up due to space charge forces with a solenoid magnet. The solenoid magnet has recently been manufactured to our specifications at PSI. In the test stand, the solenoid is sealed off from the vacuum surroundings by a UHV-compatible welded steel casing. We wanted to measure the solenoid properties and verify that it fulfills design specifications, before it was definitely welded into the steel casing. The measurement procedures and results are presented in this paper.

1 Introduction

The LEG gun test stand solenoid was designed in order to focus a 100 keV electron beam emerging from the test stand cathode's pulsed FEA [2]. The location of this focus was to be roughly 150 mm downstream of the solenoid which is at the center of the diagnostic cube. Therefore, a longitudinal magnetic field of $B_z \approx 110$ mT is required on axis and the solenoid was designed to be tunable around this field strength in order to vary the focus location.

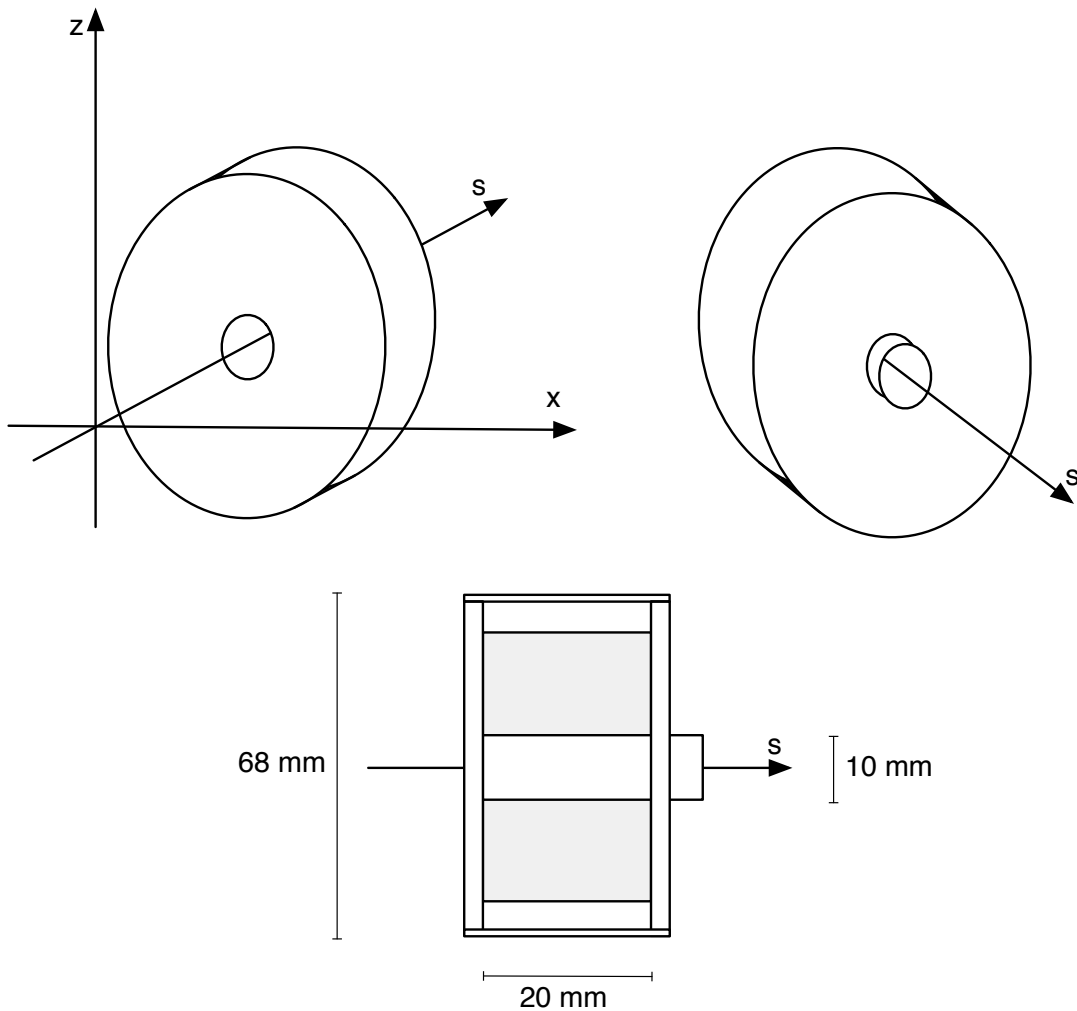

Figure 1: The gun test stand solenoid and the coordinate system used for measurements.

In the final design [3] the solenoid has 1000 copper windings capable of conducting a current of 3.6 A. The windings cover a cylinder of 20 mm length, have an inner radius of 6 mm, and an outer radius of ≈ 20 mm resulting in a longitudinal magnetic

field of $B_z \approx 200$ mT on axis (see Fig. 1). The solenoid windings are surrounded by two yoke disks and a yoke cylinder made of ARMCO, a material with a high relative magnetic permeability μ_r in order to guide the field lines and to contain the magnetic field. If a 24 V power supply is used, we expect ≈ 86 W of dissipated heat. Since this solenoid is in vacuum, we chose to use a closed water circuit for cooling; a copper heatsink disk is attached to the exit yoke disk and in turn, a copper water pipe is welded to the heatsink disk. This pipe leads cooling water to the solenoid heatsink and from there to the outside where a air-water chiller cools the liquid. A thermal sensor is attached to the center of the windings which allows us to monitor the solenoid temperature and the cooling efficiency.

2 Measurements

Magnetic field measurements of the gun test stand solenoid were performed on March 9, 2005 at the SLS magnet lab. For the measurements we used a longitudinal Hall probe connected to a Gaussmeter; the Hall probe was held in place by an aluminum cylinder which we mounted to a 3D linear mover. The cylinder had a diameter of roughly 6 mm allowing us to move it through the solenoid on and off axis. The solenoid was clamped to the base of the 3D linear mover; the Hall probe cylinder was centered vertically and horizontally within the solenoid's 10 mm aperture by eye and its horizontal inclination was adjusted with a water level. The remaining uncertainty was given by the unknown exact location and alignment of the Hall probe within its cylinder.

The solenoid was powered by a digital 24 V power supply. The power supply is the same model used for the SLS corrector magnets. Its digital control interface allows setting a current between 0 - 10 A which is kept constant by adjusting the voltage. The solenoid windings have been measured to have 6.61Ω resistance at room temperature; assuming this temperature remains constant, the power supply should be capable of delivering 3.6 A at 24 V. Due to Joule heating during operation, the ohmic resistance is expected to rise, thus reducing the maximum achievable current.

The coordinate system of the 3D linear mover is depicted in Fig. 1. Shifts in positive s direction are in the direction of beam motion. We chose to set $s = 0$ when the Hall probe cylinder's front surface (where the Hall probe is assumed) is at a location 10 mm upstream of the entry yoke disk; the solenoid center is at $s = 24$ mm due to the 4 mm thickness of the yoke disk. x and z are zero at the radial center of the solenoid, i.e. on axis.

The Gaussmeter displays the longitudinal magnetic field B_z in units of Gauss. Throughout this paper, we shall however use the common SI unit Tesla. The Gaussmeter was calibrated in such a way that it showed 0.0 mT at the center of the solenoid while the power supply was on, but set to 0.0 A current. Once the Hall probe was moved outside of the solenoid, the Gaussmeter showed increasing field strength; this is due to the fact that the solenoid shields its inside from the earth magnetic field. The effect is shown in Fig. 2 where one clearly sees how the solenoid shields a background field on the order of 0.3–0.4 mT (in good agreement with the earth magnetic field strength) at its center.

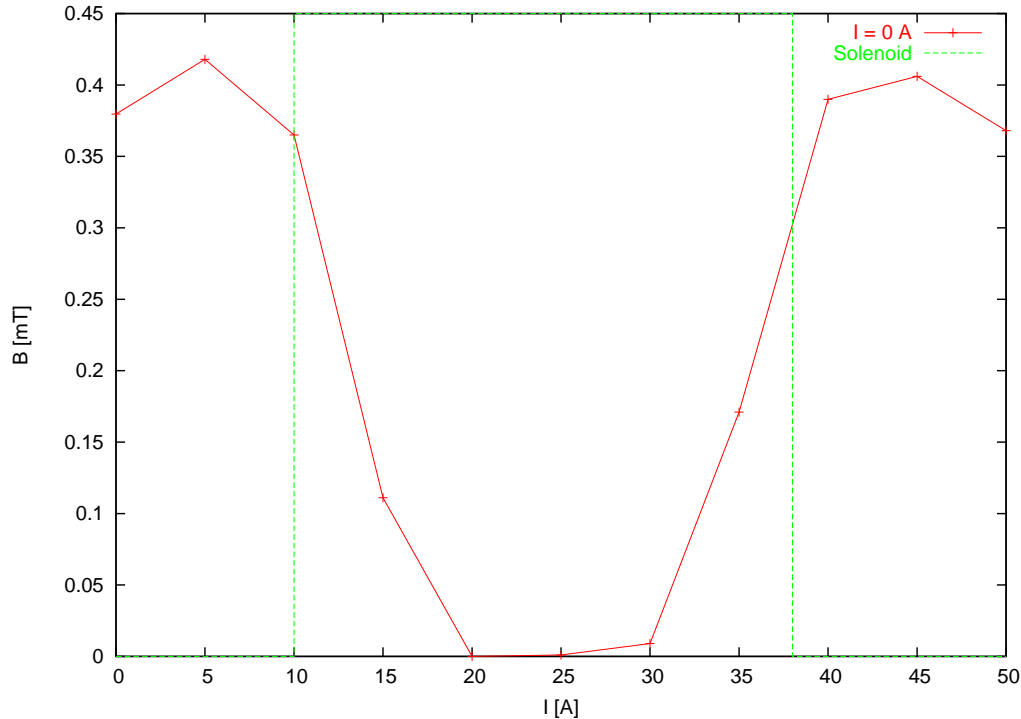

Figure 2: The background measurement showing how the solenoid (green dotted line indicates the solenoid edges) shields the earth magnetic field strength.

2.1 Field Calibration

In a first experiment, we measured the relationship between applied solenoid current and longitudinal magnetic field in the solenoid center. We positioned the calibrated Hall probe at $s = 24$ mm and on axis. For various current settings, we measured the resulting longitudinal magnetic field as depicted in Fig. 3.

Starting at 0.0 A, we increased the current until we reached 3.2 A where we hit the power supply's voltage limit of 24 V. This setting reveals an ohmic resistance of $\Omega = 7.5$ Ohm, which is slightly higher than the resistance we had originally measured at room temperature. The increase is due to the heating of the (uncooled) solenoid windings; at a current of 3.2 A, the temperature of the windings had reached 79° C.

The result shows a linear dependency between longitudinal magnetic field and applied current; per Ampere of current, the longitudinal field at the center of the solenoid grows by 58 mT. This linear dependency confirms that we are well away from saturation of the solenoid material. The required field strength of roughly 120 mT can thus be easily reached with this solenoid; tuning of the solenoid around this value should cause no problems. After reaching the maximum current, the current was reduced to zero again and the resulting field was compared to the initially measured field. A difference of roughly 2 mT was measured which shows only slight hysteresis.

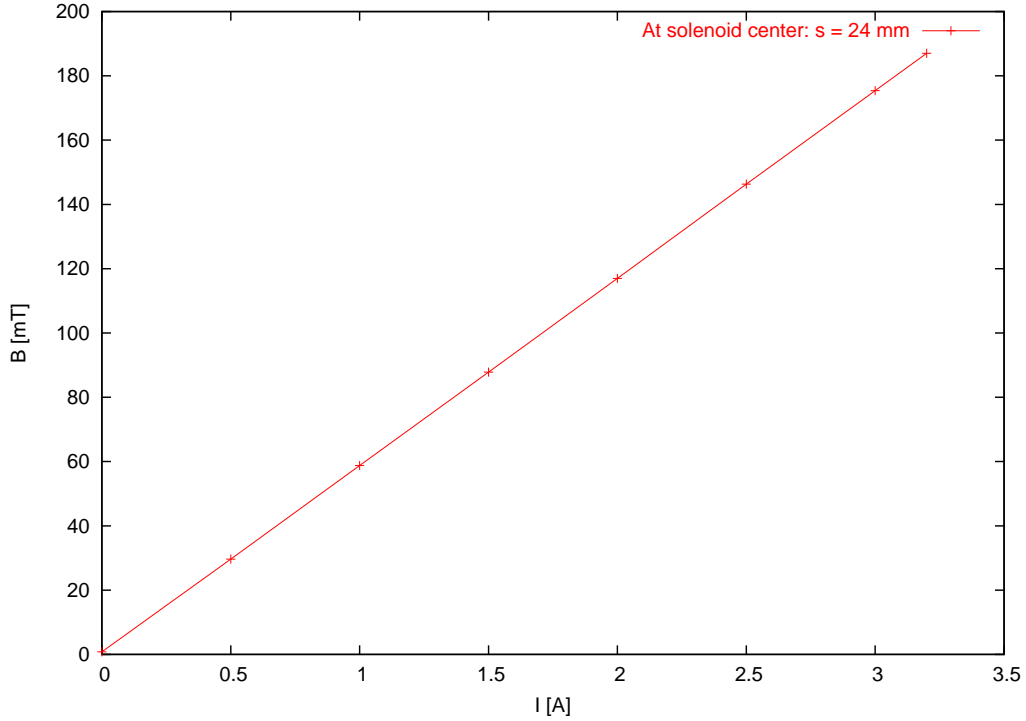

Figure 3: The calibration curve for the solenoid. The field measurement was performed at $s = 24$ mm which is at the center of the solenoid.

2.2 Longitudinal Scans

In the next experiment we measured the longitudinal magnetic field induced by the solenoid at different longitudinal positions on as well as off axis. The current setting for these scans was 2.0 A. The scanning range was between $s = -50$ mm and $s = +90$ mm which corresponds to a location 60 mm before the solenoid's entry yoke disk respectively 52 mm behind the exit yoke disk.

For the off-axis measurement we moved the Hall probe away from the axis in x and z direction by $\Delta x = +1$ mm and $\Delta z = +1$ mm, giving a radial offset of 1.4 mm. This is more than the maximum offset we expect for the beam center, since this location is in the shadow of the anode iris ($r_{iris} = 750 \mu\text{m}$). The measured field strengths for both scans are shown in Fig. 4.

The difference between on and off axis scans are plotted in Fig. 5. At the beginning of the scan, the field strength on axis is higher than off axis and this difference grows with the fringe field. At the entry of the windings the sign of this difference changes and the field strength off axis remains larger within the volume enclosed by the solenoid windings. At the solenoid exit there is again a change of sign and the on axis field strength is larger than the off axis field strength throughout the fringe field. The maximum differences are found in the fringes and are on the order of roughly

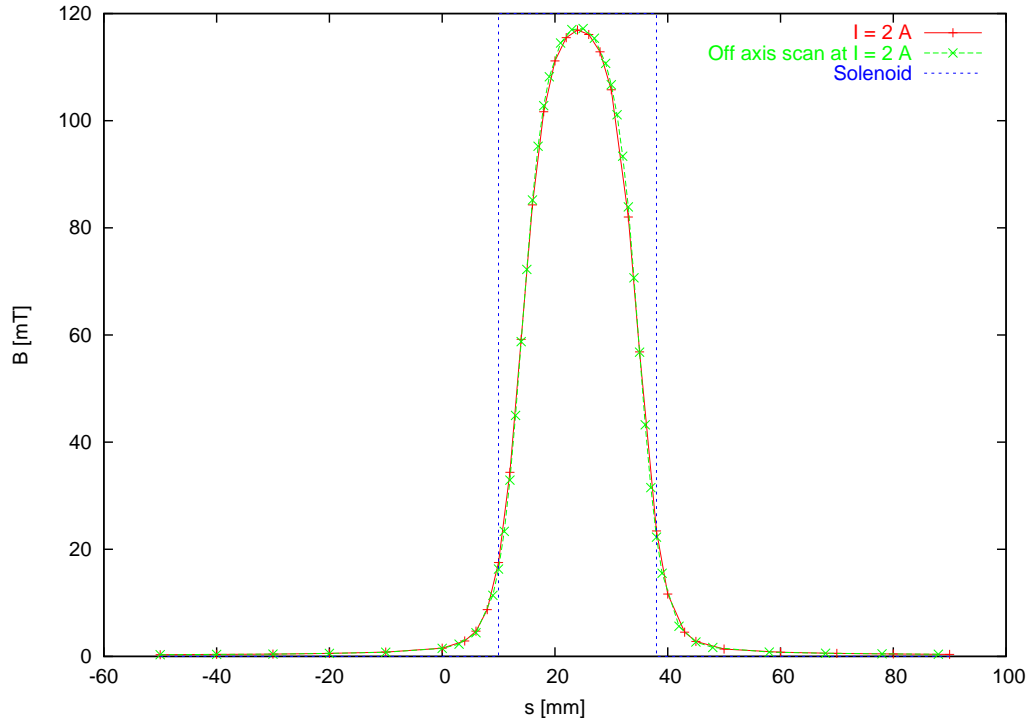

Figure 4: Two measurement curves showing data taken from longitudinal scans on and off axis. The blue dotted line indicates the location of the solenoid edges.

1.5 mT or 7%. Far outside the solenoid the differences are about 1%; at the center of the solenoid we measured 1–2% difference. In the plots shown in Fig. 5, the missing difference bars within the solenoid are due to a lack of measurement at common s positions, not due to vanishing difference.

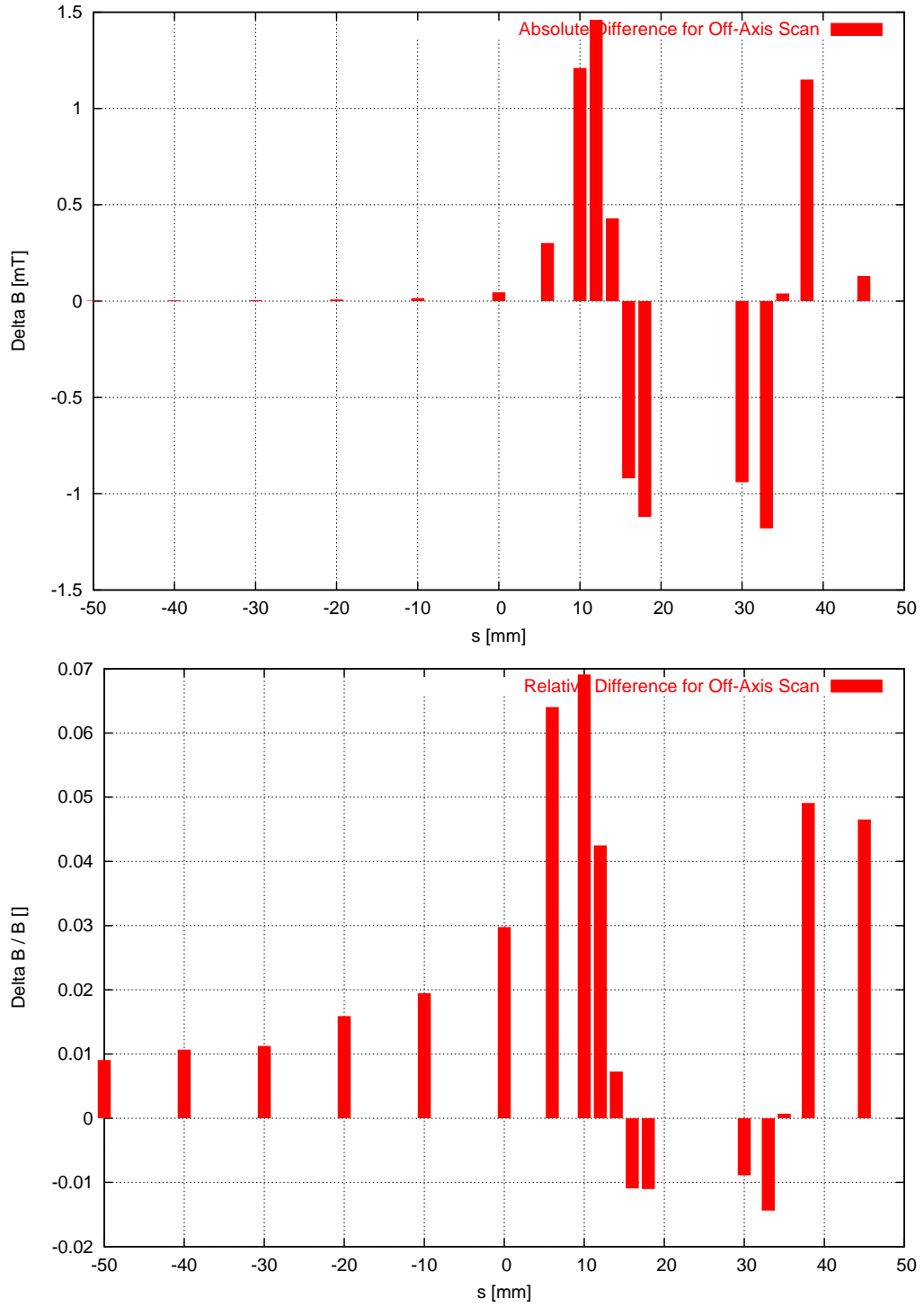

Figure 5: Absolute and relative difference between on and off axis longitudinal scans.

2.3 Fringe Field Scans

In a final experiment, we scanned the fringe field in front of the solenoid. The Hall probe was brought into position at $s = 9$ mm which is 1 mm in front of the entry yoke disk. The current of the solenoid windings was again set to 2.0 A. We scanned in x direction from -7 mm to +7 mm in steps of $\Delta x = 1$ mm and in z direction from -7 mm to +7 mm in steps of $\Delta z = 1$ mm. Both measurement curves are plotted in Fig. 6.

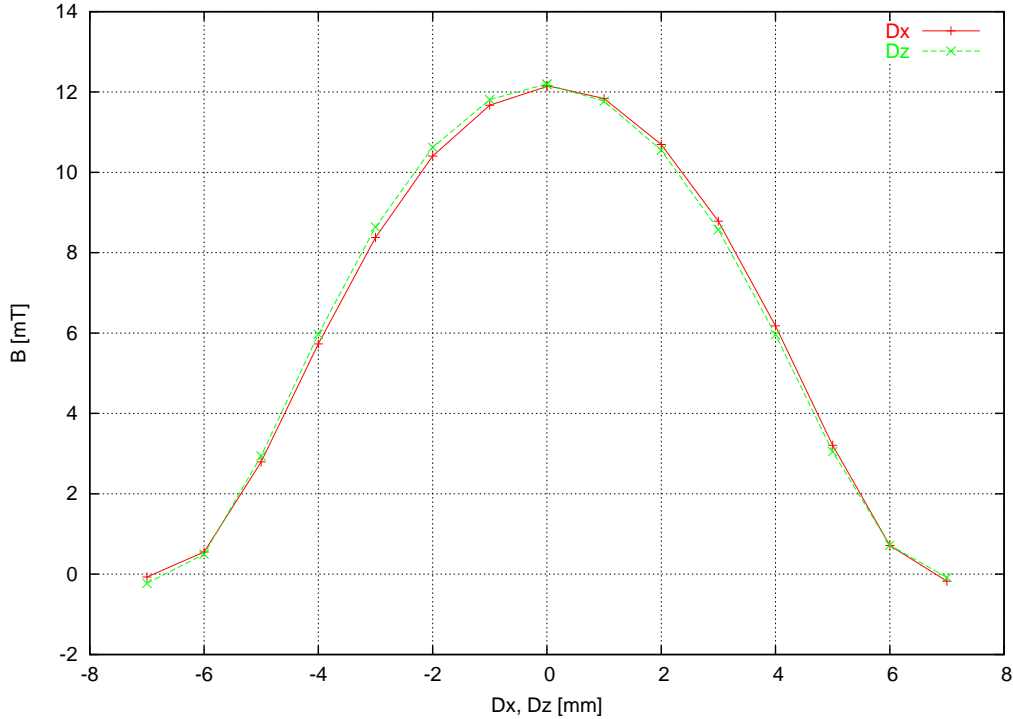

Figure 6: Longitudinal magnetic field measurement in the solenoid fringe field. The two curves show scans for varying Δx respectively Δz .

The longitudinal magnetic field at the far outer measurement positions (± 7 mm) vanishes. As the Hall probe is moved towards the solenoid axis, the field strength increases to 12 mT. For both scans the field strength shows symmetrical behavior on either side. Qualitatively the field strengths are identical for x and z direction scans which indicates azimuthal symmetry of the solenoid. The minor difference between the two curves is a slight systematic shift of the Δz curve to the left of the Δx curve, which we assume comes from a marginal misalignment of the Hall probe with respect to the solenoid, i.e. the Hall probe was not perfectly centered within the solenoid for both the x and the z plane.

3 Conclusions

From these measurements we gather a set of conclusions for the operation of the solenoid in the gun test stand: The only observable hysteresis effects are within 1–2 mT. Water cooling is necessary in order to transport dissipated heat to the outside, otherwise the solenoid will quickly heat up to temperatures above 100° C. The solenoid is operated well away from saturation within the entire tuning range of the power supply. The longitudinal magnetic field shows longitudinal symmetry, the longitudinal fringe field shows azimuthal symmetry. Misalignment tolerance is high since only slight differences were measured for on and off axis longitudinal fields.

4 Acknowledgments

We would like to thank Andreas Streun for the solenoid design and his comments and suggestions concerning the measurement procedure. We are grateful to Dave George for lending us the Gaussmeter and Hall probes. Matt Horvat is acknowledged for his help with the digital power supply and its controls. Finally we would like to express our sincere gratitude to Bruno Jakob and Christian Vollenweider for their help with the experimental setup and the linear movers. Thanks to the quick and uncomplicated support we received from these people, the measurements could be carried out in the narrow timeframe given by test stand construction work.

References

- [1] The Low Emittance Gun Project LEG at PSI, <http://leg.web.psi.ch>
- [2] S. C. Leemann, *100 keV Gun Test Stand: Design and Parameter Study*, SLS internal note SLS-TME-TA-2004-0244, 2004.
- [3] A. Streun, *Entwurf eines Solenoids für den 100 keV Gun Teststand*, unpublished internal note.